



Type 3232 can be combined with...



#### Type 2030/31

Version with  
pneumatic actuator

Manually-operated diaphragm valves in compact model consisting of plastic bodies, diaphragm seal, PPS bonnet and PPS handwheel. The diaphragm is both a switching element and a seal element towards the outside, and is easily replaced. The flow can be continually adjusted with the handwheel. The valves have no dead volume and can be mounted to be self-draining.

#### Installation for self-draining operation

$\alpha = 15$  to  $30^\circ$  plus  $3^\circ$  to  $5^\circ$  inclination to pipe axis

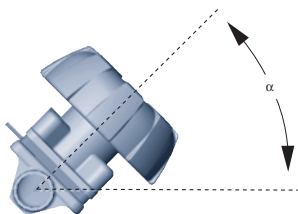

## 2/2-way Diaphragm Valve with plastic body, manually operated, DN 15-50

- Application with aggressive media
- Flow-optimised body
- Zero dead volume
- Removable radial true union and spigot connections
- Self-draining

Technical data	
Orifice	DN 15 - 50 (65-100 on request)
Body materials	PVC-U, PP, PVDF
Actuator material	PPS manual actuator and bonnet
Seal material	EPDM, PTFE/EPDM (FKM on request)
Medium	Neutral or aggressive medium
Viscosity	Up to viscous
Medium temperature <sup>1)</sup>	See chart on p. 2
Ambient temperature	-10 to +60 °C
Port connections	True union and spigot
Installation	As required
Installation for self draining	Tilted 5 to 30° to the horizontal and Inclined 3 to 5° to the flow direction (see drawing)
Options (on request)	Locking function

<sup>1)</sup> The permissible nominal pressure falls with increasing medium temperature (see Pressure-temperature chart)

## Ordering chart for valves (other versions on request)

All bonnets and handwheels are manufactured from PPS

Orifice DN [mm]	Orifice DN [inch]	Connection internal Ø [mm]	Kv value water [m <sup>3</sup> /h]	Pressure range at +20°C [bar]	Item no. EPDM diaphragm	Item no. EPDM/ PTFE diaphragm
<b>Body in PVC</b>						
<b>True union connection</b>						
15	1/2	20	3.5	0 - 10	144 758	144 764
20	3/4	25	7.2	0 - 10	144 759	144 765
25	1	32	12.5	0 - 10	144 760	144 766
32	1 1/4	40	19.0	0 - 10	144 761	144 767
40	1 1/2	50	28.0	0 - 10	144 762	144 768
50	2	63	40.0	0 - 7	144 763	144 769
<b>Spigot connection</b>						
15	1/2	20	3.5	0 - 10	144 770	144 776
20	3/4	25	7.2	0 - 10	144 771	144 777
25	1	32	12.5	0 - 10	144 772	144 778
32	1 1/4	40	19.0	0 - 10	144 773	144 779
40	1 1/2	50	28.0	0 - 10	144 774	144 780
50	2	63	40.0	0 - 7	144 775	144 781
<b>Body in PP</b>						
<b>True union connection</b>						
15	1/2	20	3.5	0 - 10	144 782	144 788
20	3/4	25	7.2	0 - 10	144 783	144 789
25	1	32	12.5	0 - 10	144 784	144 790
32	1 1/4	40	19.0	0 - 10	144 785	144 791
40	1 1/2	50	28.0	0 - 10	144 786	144 792
50	2	63	40.0	0 - 7	144 787	144 793
<b>Spigot connection</b>						
15	1/2	20	3.5	0 - 10	144 794	144 800
20	3/4	25	7.2	0 - 10	144 795	144 801
25	1	32	12.5	0 - 10	144 796	144 802
32	1 1/4	40	19.0	0 - 10	144 797	144 803
40	1 1/2	50	28.0	0 - 10	144 798	144 804
50	2	63	40.0	0 - 7	144 799	144 805
<b>Body in PVDF</b>						
<b>True union connection</b>						
15	1/2	20	3.5	0 - 10	144 806	144 812
20	3/4	25	7.2	0 - 10	144 807	144 813
25	1	32	12.5	0 - 10	144 808	144 814
32	1 1/4	40	19.0	0 - 10	144 809	144 815
40	1 1/2	50	28.0	0 - 10	144 810	144 816
50	2	63	40.0	0 - 7	144 811	144 817
<b>Spigot connection</b>						
15	1/2	20	3.5	0 - 10	144 818	144 824
20	3/4	25	7.2	0 - 10	144 819	144 825
25	1	32	12.5	0 - 10	144 820	144 826
32	1 1/4	40	19.0	0 - 10	144 821	144 827
40	1 1/2	50	28.0	0 - 10	144 822	144 828
50	2	63	40.0	0 - 7	144 823	144 829

**Note:** The permissible nominal pressure falls with increasing medium temperature (see Pressure-temperature chart next page).

 Further versions on request

 **Material**  
Sealing: FKM

 **Port connection**  
Orifice 65-100

 **Additional**  
Versions with locking function

## Materials

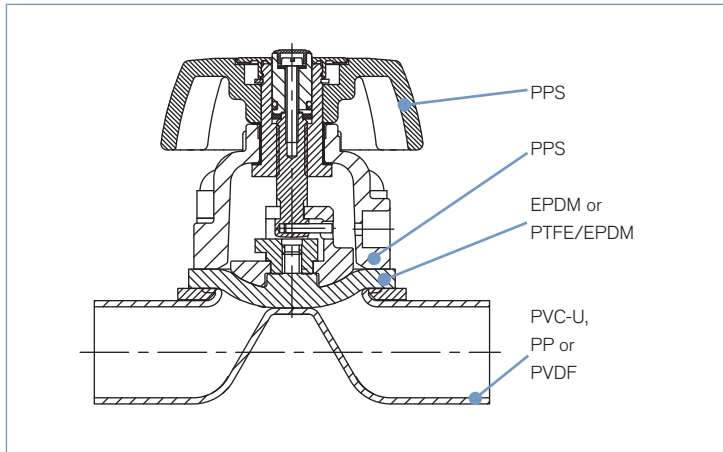

## Approvals

### Suitable for foodstuffs



- The composition of the EPDM and PTFE/EPDM diaphragms corresponds to the *Code of Federal Regulations*, published by the *FDA* (Food and Drug Administration, USA).

## Medium temperature

### Pressure-temperature compatibility chart

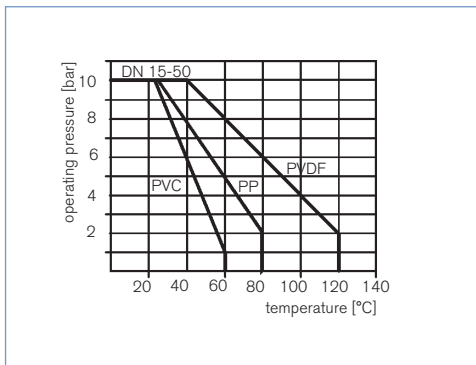

## Dimensions [mm]

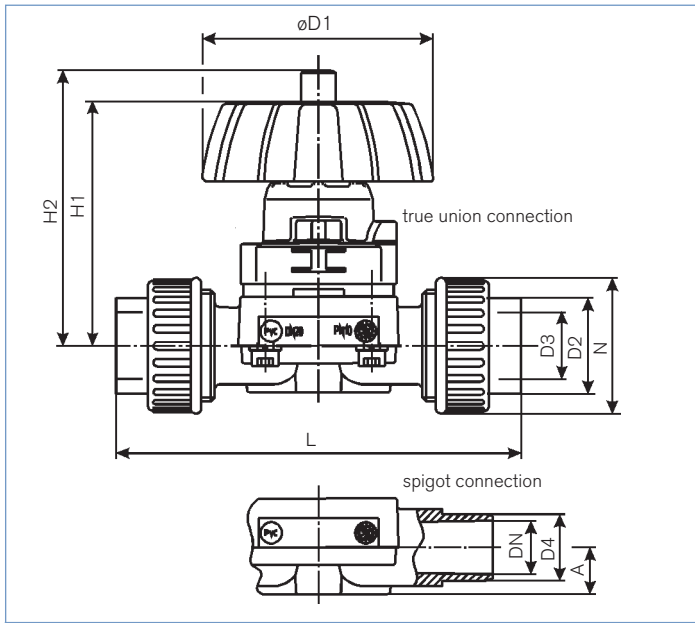

All versions				True union connection				Spigot connection		
DN	$\varnothing D1$	H1	H2	D2	D3	L	N	A	D4	L
15	86	84	92	28	20	128	41	14	20	124
20	86	92	102	36	25	152	51	17.5	25	144
25	86	96	108	42	32	166	58	21	32	154
32	114	124	139	53	40	192	72	25.5	40	174
40	114	130	149	59	50	222	80	32.5	50	194
50	114	145	170	74	63	266	100	39	63	224

To find your nearest Bürkert facility, click on the orange box →

[www.burkert.com](http://www.burkert.com)In case of special application conditions,  
please consult for advice.Subject to alteration.  
© Christian Bürkert GmbH & Co. KG

1111/6\_EU-en\_00891912