



2-way Diaphragm Control Valve, forged stainless steel body, pneumatically operated, DN 15-100

- Hermetical separation of fluids from the operating mechanism by diaphragm
- Integrated cascade process controller with PID algorithm
- Automatic self-adjustment of basic parameters means autotune for the valve and for PID
- Zero dead volume

Type 2731 can be combined with...



Type 8694

Positioner
TopControl Basic



Type 8692/8693

Positioner / Process
Controller TopControl



Type 8630

Positioner
TopControl



Type 8635

Positioner
SideControl



Type 8792/93

SideControl Remote
versions



Type 8030

Flow sensor

The diaphragm control valve Type 2731 consists of a pneumatically operated piston actuator, a diaphragm and a valve body from forged stainless steel.

The actuator has been designed so that the stroke can be continuously changed. This makes a favourable characteristic possible for the continuous change of the flow.

The Type 2731 can be actuated by the 8635 SideControl, SideControls 8792/93 Remote versions or the 8694/8692/8693/ 8630 TopControl forming a mechanical and functional unit and thus offering a complete control valve system. Using this control valve, continuous regulation tasks for fluids can be solved.

Proven Applications

- Pharmaceutical Industry
- Biotechnology
- Food Industry

Technical data	
Materials	
Body	Forged st. st. 1.4435/316L/BN2 Fe <0.5%/C ≤0.03%
Actuator	Actuators Ø80-125 mm: PPS (PA polyamide on request) Actuators Ø175 and 225 mm: PA polyamide
Sealing	EPDM, PTFE/EPDM (advanced PTFE/EPDM, FKM on request)
Process medium	For neutral gases and liquids, high purity, sterile aggressive or abrasive fluids
Viscosity	Up to viscous (average surface finish)
Surface finishes	
internal mechanical polished (external forged surface)	Ra ≤ 0.5 µm
<i>On request</i>	
internal electro polished (external forged surface electro polished)	Ra ≤ 0.4 µm
internal mirror finished	Ra ≤ 0.25 µm
Medium temperatures	
EPDM, PTFE/EPDM, advanced PTFE/EPDM ¹⁾ , FKM on request	-10 to +130°C (briefly up to +150°C for steam sterilisation) -10 to +130°C
Ambient temperature	-10° to +60°C, Actuators ≥175 mm: -10° to +50°C
Control medium (for coupling with a positioner)	Instrumental air class 3 acc. to DIN ISO 8573-1
Pilot pressure	Actuators Ø80 to 125 mm: 5.5 to 7 bar Actuators Ø175 and 225 mm: 5 to 6 bar
Pilot air ports	G1/4 (stainless steel)
Flow characteristic	See chart p. 2
Port connections	
Weld end	EN ISO 1127/ISO 4200, DIN 11850 S2 (on request SMS 3008, ASME BPE, DIN 11850 S0, 1, 3, JIS and BS4825)
On request clamp	DIN 32676, ISO 2852, ASME BPE
Installation	As required, preferably with actuator in upright position

1) Advanced PTFE/EPDM is recommended for sterilization cycle

Content

Valve specifications	System spec. Continuous Classic	Request for quotation
Type 2731 forged	Type 8802-DD	Type 8802-DD
Technical data & ordering info. p. 1-5	Ordering info. & technical data p. 6-12	p. 13



Technical data, continued

Kvs values and weights

Orifice [mm]	Actuator size [mm]	Kvs value [m ³ /h]	Weight without positioner [kg]
15	80	4.5	1.9
20	80	7.5	2.0
25	80	12.5	2.2
40	125	30.0	6.9
50	125	51.5	7.6
65	175	160	19
80	225	160	26
100	225	235	38

Flow characteristic

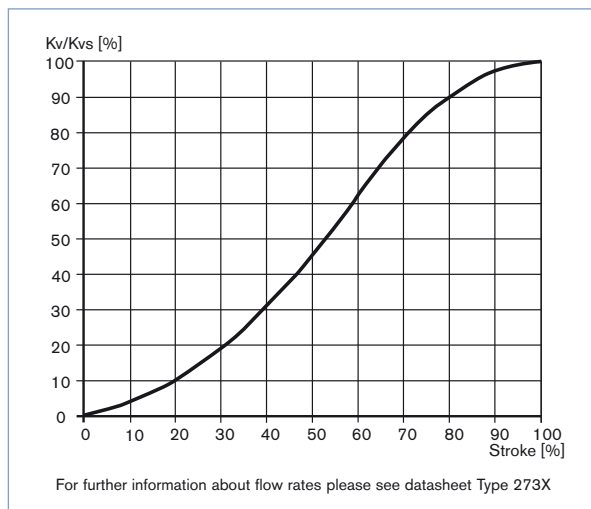

Installation for self-draining operation

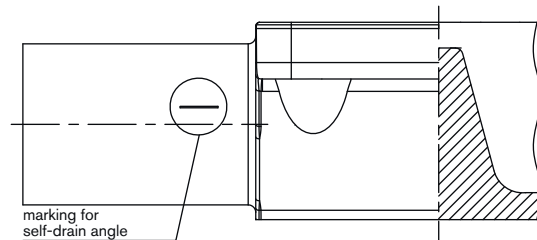
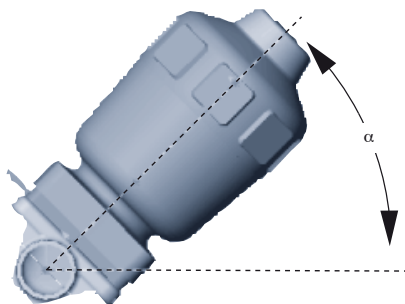

$\alpha = 15$ up to 35° (Marking must face upwards, 12 o'clock position)
plus 3° to 5° inclination to the pipe axis.
Drain marks permanently marked on both sides of the valve body
show the correct mounting position to optimise drain ability.

Materials

DN 15-50

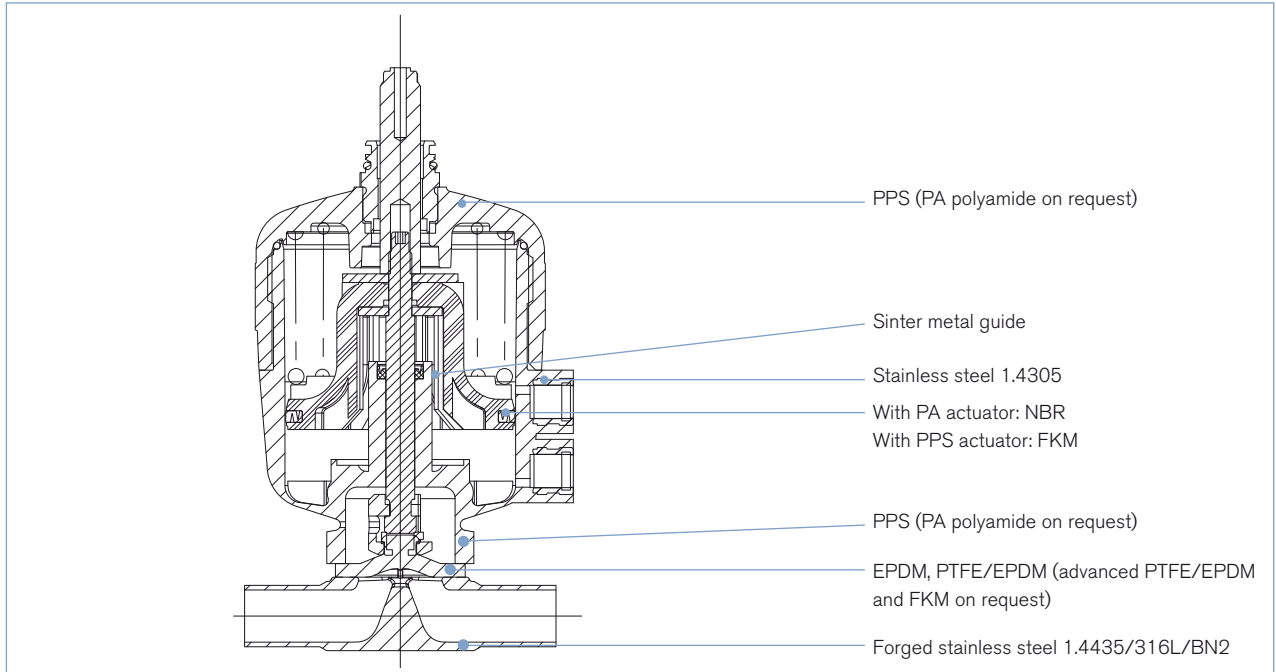

DN 65-100

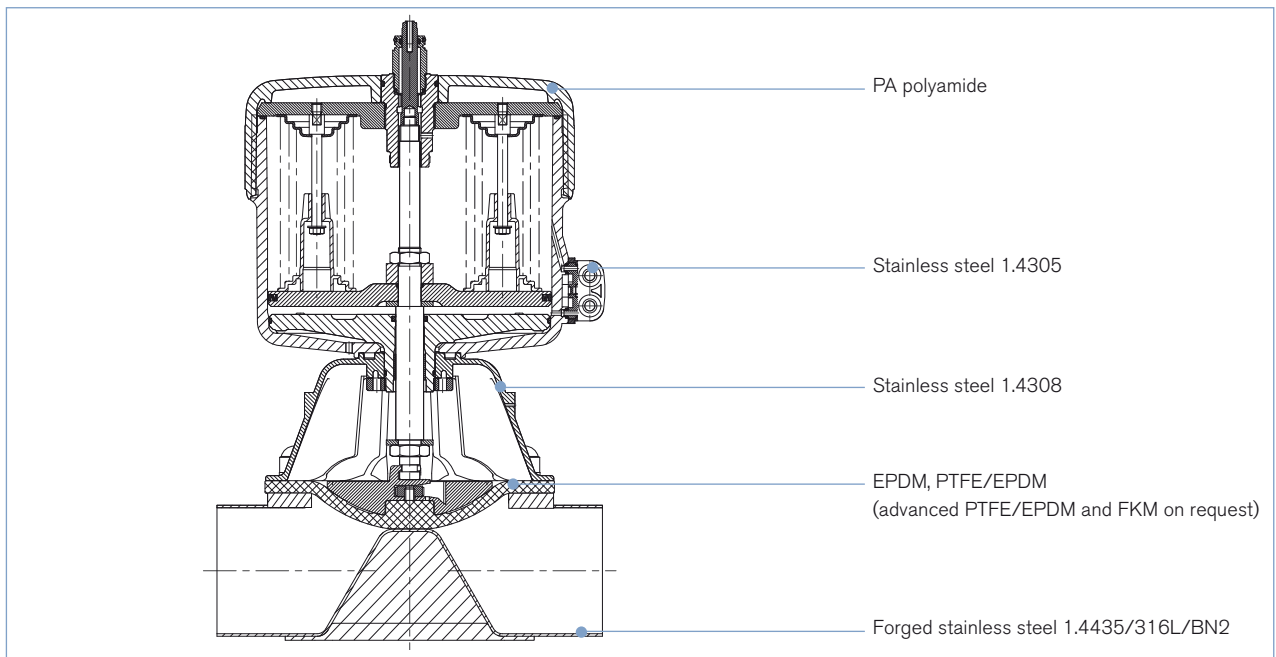

Approvals

Suitable for foodstuffs / sterile applications



▪ The composition of the EPDM, PTFE/EPDM and advanced PTFE/EPDM diaphragms corresponds to the *Code of Federal Regulations*, published by the *FDA* (Food and Drug Administration, USA).

▪ The EPDM diaphragms correspond to the *KTW-Recommendation* (Plastics in the Drinking Water Sector).



A Manufacturer's Declaration will be supplied on request.

▪ The diaphragm valves are 3-A approved (3-A Sanitary Standards Symbol Administrative Council)

Ordering chart valve

Weld end acc. to EN ISO 1127/ISO 4200

Actuators Ø80-125 mm; PPS, actuators Ø175-225 mm; PA, internal mechanical polished; average surface 0.5 µm

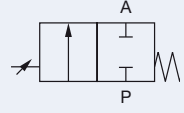
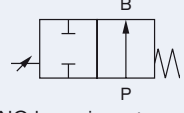
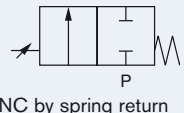
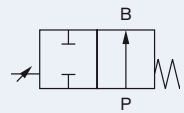
Control function	Port connection [mm]	Actuator size Ø [mm]	Kvs value [m ³ /h]	Operating pressure max. ¹⁾ [bar]	Item no.	
EN ISO 1127/ISO 4200						
EPDM diaphragm material						
A  NC by spring return	15	80	4.5	10	155 184	
	20	80	7.5	10	155 186	
	25	80	12	10	155 188	
	40	125	30	6.5	155 190	
	50	125	51.5	8	155 191	
	65	175	160	10	■	
	80	225	160	10	■	
B  NO by spring return	15	80	4.5	10	155 193	
	20	80	7.5	10	155 195	
	25	80	12	10	155 197	
	40	125	30	10	155 199	
	50	125	51.5	7	155 201	
	65	175	160	10	■	
	80	175	160	10	■	
PTFE/EPDM diaphragm material	A  NC by spring return	15	80	4.5	10	155 185
		20	80	7.5	10	155 187
		25	80	12	7.5	155 189
		40	125	30	6	154 864
		50	125	51.5	7	155 192
		65	175	160	8.5	■
		80	225	160	10	■
	B  NO by spring return	15	80	4.5	9	155 194
		20	80	7.5	8.5	155 196
		25	80	12	8	155 198
		40	125	30	10	155 200
		50	125	51.5	4	155 202
		65	175	160	10	■
80	175	160	9	■		
100	175	235	5	■		

1) with a pilot pressure of 5.5 bar

■ on request

 Further versions on request
**Material**Actuator: PA (actuator size 80-125 mm)
Sealing: advanced PTFE/EPDM, FKM**Port connection**Weld end body acc. to SMS 3008, ASME BPE, DIN 11850 S0, 1, 3, JIS and BS4825
Clamp body acc. to DIN 32676, ISO 2852, ASME BPE**Additional**Surface finish internal electro polished, Ra ≤ 0.4 µm and
internal mirror finished, Ra ≤ 0.25 µm

Ordering chart valve, continued

Weld end acc. to DIN 11850 Series 2

Actuators Ø80-125 mm; PPS, actuators Ø175-225 mm; PA, internal mechanical polished; average surface 0.5 µm

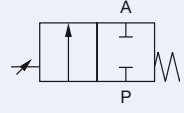
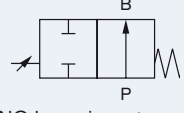
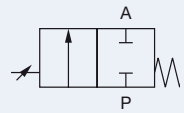
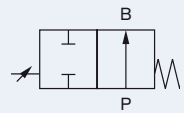
Control function	Port connection [mm]	Actuator size Ø [mm]	Kvs value [m ³ /h]	Operating pressure max. ¹⁾ [bar]	Item no.	
DIN 11850 Series 2						
EPDM diaphragm material						
A  NC by spring return	15	80	4.5	10	155 203	
	20	80	7.5	10	155 205	
	25	80	12	10	155 207	
	40	125	30	6.5	155 209	
	50	125	51.5	8	155 211	
	65	175	160	10	■	
	80	225	160	10	■	
B  NO by spring return	15	80	4.5	10	155 213	
	20	80	7.5	10	155 215	
	25	80	12	10	155 217	
	40	125	30	10	155 219	
	50	125	51.5	7	155 221	
	65	175	160	10	■	
	80	175	160	10	■	
PTFE/EPDM diaphragm material	A  NC by spring return	15	80	4.5	10	155 204
		20	80	7.5	10	155 206
		25	80	12	7.5	155 208
		40	125	30	6	154 210
		50	125	51.5	7	155 212
		65	175	160	8.5	■
		80	225	160	10	■
	B  NO by spring return	15	80	4.5	9	155 214
		20	80	7.5	8.5	155 216
		25	80	12	8	155 218
		40	125	30	10	155 220
		50	125	51.5	4	155 222
		65	175	160	10	■
		80	175	160	9	■
100	175	235	5	■		

1) with a pilot pressure of 5.5 bar

■ on request

 Further versions on request
**Material**Actuator: PA (actuator size 80-125 mm)
Sealing: advanced PTFE/EPDM, FKM**Port connection**Weld end body acc. to SMS 3008, ASME BPE, DIN 11850 S0, 1, 3, JIS and BS4825
Clamp body acc. to DIN 32676, ISO 2852, ASME BPE**Additional**Surface finish internal electro polished, Ra ≤ 0.4 µm and
internal mirror finished, Ra ≤ 0.25 µm

Ordering information for valve system Continuous Classic Type 8802-DD

A valve system Continuous Classic Type 8802-DD consists of an diaphragm control valve Type 2731 and a digital electropneumatic Positioner Type 8692, a digital electropneumatic Process Controller Type 8693, a digital electropneumatic Positioner Basic Type 8694 (below) or a valve actuation system TopControl Type 8630, SideControl Type 8635 or an electropneumatic positioner Type 8792/8793 (next page) (see separate datasheets). For the configuration of further valve systems please use the "Request for quotation" on p. 13 [go to page](#)

You order two components and receive a complete assembled and certified valve.

Ordering the valve system Continuous Classic Type 8802-DD

Diaphragm control valve Type 2731



Positioner



Positioner
Type 8692



Process Controller
Type 8693



Positioner Basic
Type 8694

Diaphragm control valve with desired positioner



Valve system
Continuous
Classic
Type 8802-DD-I
2731 + 8692



Valve system
Continuous
Classic
Type 8802-DD-J
2731 + 8693



Valve system
Continuous
Classic
Type 8802-DD-L
2731 + 8694

When you click on the orange box "More info." below, you will come to our website for the resp. product where you can download the datasheet.

Positioner TopControl Type 8692

More
info.



Process Controller TopControl Type 8693

More
info.



The new generation of integrated positioners/process controllers for combination with actuators from the process valve series Type 23xx/2103 is specially designed for the requirements of hygienic process environments. The easy handling and the selection of additional software functions are done either on a big graphic display with backlight and keypad or via a PC interface. A contact-free analogue position sensor registers the valve position without deterioration. Single-acting or double-acting actuators are controlled via the integral positioner system. With Type 8693, the process controller function is superimposed on the position control loop. Profibus DPV1 and DeviceNet communication interfaces are available as options. Main customer benefits:

- Compact design of the valve system with integrated positioner/process controller meets the demands for plant washdown environments through the selection of materials, external seals and integrated control air supply to the actuator
- Extremely simple commissioning and operation thanks to the backlighting of the graphics display and proven multilingual software structure
- Automatic parameterisation of the positioner and process controller using the TUNE functions
- Field bus communication via Profibus DPV1 or DeviceNet
- Air intake filter enhances the process valve system availability
- Simple and reliable actuator adaption
- Explosion-proof models for zone 2/22

Positioner TopControl Basic Type 8694

More
info.



The new generation of integrated positioners for combination with actuators from the process valve series Type 23xx/2103 is specially designed for the requirements of hygienic process environments. The operation and selection of the software functions close tight function, inversion of the operating direction of the setpoint signal, characteristic curves selection and switching manual/automatic operation are effected via push-buttons and DIP switches or via the PC interface. The position setpoint is set using the standard signal 4 - 20 mA. In addition, the enable can be controlled via the binary input and an optional position feedback can be integrated. The positioner, Type 8694, registers the valve position without deterioration through a contact-free analogue position sensor. Single-acting or double-acting actuators are controlled via the integral positioner system. An AS-Interface communication interface is available as an option. Main customer benefits:

- Compact design of the valve system with integrated positioner meets the demands for plant washdown environments through the selection of materials, external seals and integrated control air supply to the actuator
- Automatic parameterisation of the process controller using the Process TUNE function
- Field bus communication via optional AS-Interface
- Air intake filter enhances the process valve system availability
- Simple and reliable actuator adaption allowing additional actuators of the process valve series, Type 20xx or actuators from other manufacturers to be used
- Explosion-proof models for zone 2/22

Ordering information for valve system Continuous Classic Type 8802-DD, continued

A valve system Continuous Classic Type 8802-DD consists of an diaphragm control valve Type 2731 and a digital electropneumatic Positioner Type 8692, a digital electropneumatic Process Controller Type 8693, a digital electropneumatic Positioner Basic Type 8694 (previous page) or a valve actuation system TopControl Type 8630, SideControl Type 8635 or an electropneumatic positioner Type 8792/8793 (below) (see separate datasheets). For the configuration of further valve systems please use the "Request for quotation" on p. 13 [go to page](#)

You order two components and receive a complete assembled and certified valve.

Ordering the valve system Continuous Classic Type 8802-DD

Diaphragm control valve
Type 2731

Positioner



Positioner/
Process Controller
Type 8630



Positioner/
Process Controller
Type 8635



Positioner
Type 8792/
Process
Controller
Type 8793

Diaphragm control valve
with desired positioner



Valve system
Continuous Classic
Type 8802-DD-A
2731 + 8630



Valve system
Continuous Classic
Type 8802-DD-B
2731 + 8635



Valve system
Continuous Classic
Type 8802-DD-P
2731 + 8792 /
Type 8802-DD-Q
2731 + 8793

When you click on the orange box "More info." below, you will come to our website for the resp. product where you can download the datasheet.

TopControl Type 8630

More info.



0/4-20 mA
0-5/10 V

PROFIBUS
DeviceNet™



The Type 8630 is an electro-pneumatic positioner for usage with pneumatically operated process valves. The compact design with integrated position encoder and LCD display was developed for demanding applications of the process industry.

Main customer benefits are:

- Time saving algorithms for temperature, flow and pressure PID parameters through ProcessTUNE function.
- Quick and simple menu driven parameterization through keyboard
- Field bus communication via Profibus DPV1 or DeviceNet
- Fits seamlessly to Bürkert's process valve systems
- Break resistant housing
- Suitable for hazardous locations per zone 2 and 22

SideControl Type 8635, 2-wire,
intrinsically safe

More info.



4-20 mA

PROFIBUS
DeviceNet™



Type 8635 is a digital electro-pneumatic positioner with an optional, integrated process controller for precise control requirements. The compact design with integrated position encoder and LCD display was developed for demanding applications of the process industry.

Main customer benefits are:

- Time saving algorithms for temperature, flow and pressure PID parameters through ProcessTUNE function.
- Quick and simple menu driven parameterization through keyboard or Profibus PA
- Remote setpoint adjustment via a 4-20 mA signal
- Adaptation according to IEC534-6 for lift and swivel drives
- Rugged anodised aluminium housing
- Suitable for hazardous locations per zone 1, zone 21 or zone 2 and 22

Positioner SideControl Type 8792

More info.

Process Controller SideControl Type 8793

More info.



PROFIBUS
DeviceNet™



Type 8792/8793 is a digital electro-pneumatic positioner with an optional, integrated process controller (8793) for precise control requirements. The compact design with integrated position encoder and LCD display was developed for demanding applications of the process industry. A Profibus DPV1 communication interface is available as an option.

Main customer benefits are:

- Time saving algorithms for temperature, flow and pressure PID parameters through ProcessTUNE function.
- Quick and simple menu driven parameterization through keyboard or Profibus DPV1 PA
- Adaption acc. to IEC534-6 and VDI/VDE 3845 for lift and swivel drives or as a Remote version together with Bürkert process valves
- Rugged anodised aluminium housing
- Suitable for hazardous locations per zone 2/22

Dimensions for valve system Continuous Classic Type 8802-DD [mm]

Dimensions valve system Continuous Classic Type 8802-DD-I with positioner TopControl Type 8692 and 8802-DD-J with process controller TopControl Type 8693 [mm]

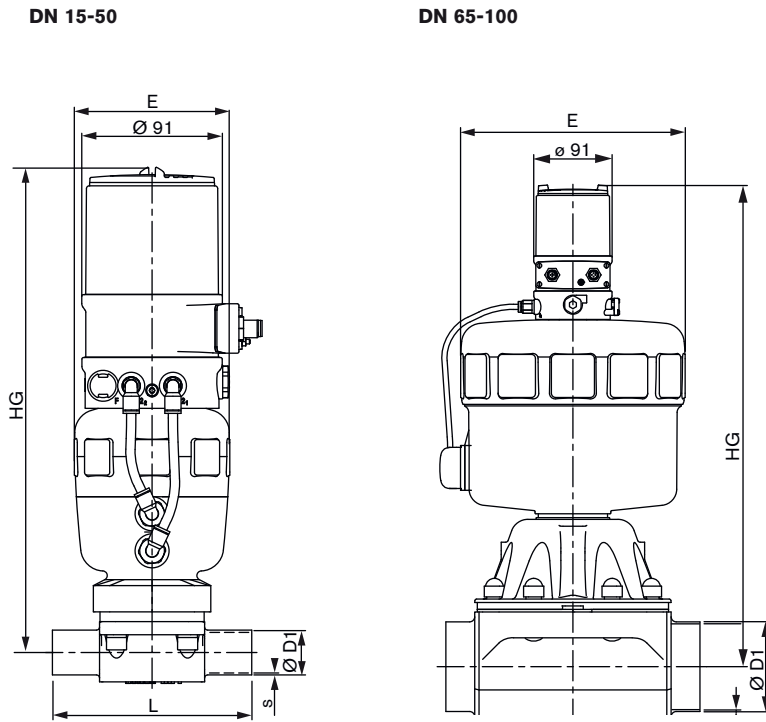

DN 15-50

Port connection [mm] [inch]	Actuator size [mm]	E	HG	L	EN ISO 1127/ ISO 4200		DIN 11850								SMS 3008		JIS		ASME BPE		
					D1	s	Series 0		Series 1		Series 2		Series 3		D1	s	D1	s	L	D1	s
							D1	s	D1	s	D1	s	D1	s							
15 1/2"	80	101	300	110	21.3	1.6	18	1.5	18	1	19	1.5	20	2	-	-	21.7	2.1	108	12.7	1.65
20 3/4"	80	101	313	119	26.9	1.6	22	1.5	22	1	23	1.5	24	2	-	-	27.2	2.1	117	19.05	1.65
25 1"	80	101	316	129	33.7	2	28	1.5	28	1	29	1.5	30	2	25	1.2	25.4	1.2	127	25.4	1.65
40 1 1/2"	125	153	408	161	48.3	2	40	1.5	40	1	41	1.5	42	2	38	1.2	38.1	1.2	159	38.1	1.65
50 2"	125	153	414	192	60.3	2	52	1.5	52	1	53	1.5	54	2	51	1.2	50.8	1.5	190	50.8	1.65

DN 65-100

Port connection [mm] [inch]	Actuator size [mm]	E	HG	L	EN ISO 1127/ ISO 4200		DIN 11850 Series 1		SMS/ASME BPE		
					D1	s	D1	s	L	D1	s
65 -	175	211	434	250	76.1	2	70	2	-	-	-
80 3"	175	211	541	250	88.9	2.3	85	2	250	76.2	1.65
	225	261	538	250	88.9	2.3	85	2	250	76.2	1.65
100 4"	175	211	557	295	114.3	2.3	104	2	295	101.6	2.11
	225	261	553	295	114.3	2.3	104	2	295	101.6	2.11

Dimensions for valve system Continuous Classic Type 8802-DD [mm], continued

Dimensions valve system Continuous Classic Type 8802-DD-L with positioner TopControl Basic Type 8694 [mm]

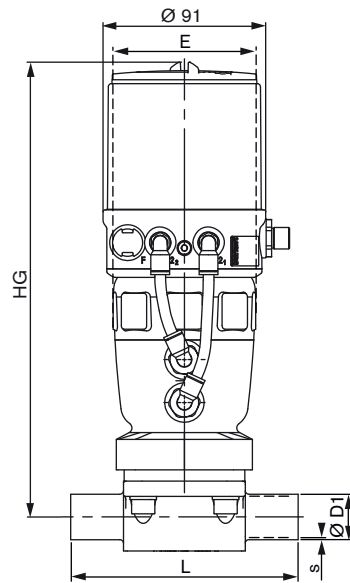

Port connection [mm] [inch]	Actuator size [mm]	E	HG	L	EN ISO 1127/ ISO 4200		DIN 11850								SMS 3008		JIS		ASME BPE		
					D1	s	Series 0		Series 1		Series 2		Series 3		D1	s	D1	s	L	D1	s
							D1	s	D1	s	D1	s	D1	s							
15 1/2"	80	101	260	110	21.3	1.6	18	1.5	18	1	19	1.5	20	2	-	-	21.7	2.1	108	12.7	1.65
20 3/4"	80	101	270	119	26.9	1.6	22	1.5	22	1	23	1.5	24	2	-	-	27.2	2.1	117	19.05	1.65
25 1"	80	101	273	129	33.7	2	28	1.5	28	1	29	1.5	30	2	25	1.2	25.4	1.2	127	25.4	1.65
40 1 1/2"	125	153	366	161	48.3	2	40	1.5	40	1	41	1.5	42	2	38	1.2	38.1	1.2	159	38.1	1.65
50 2"	125	153	372	192	60.3	2	52	1.5	52	1	53	1.5	54	2	51	1.2	50.8	1.5	190	50.8	1.65

Dimensions for valve system Continuous Classic Type 8802-DD [mm], continued

Dimensions valve system Continuous Classic Type 8802-DD-A with positioner TopControl Type 8630 [mm]

DN 15-50

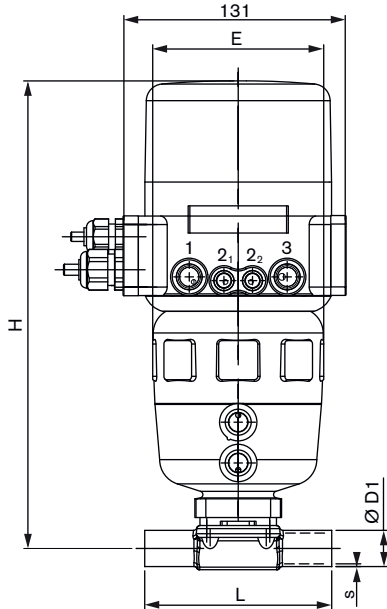

DN 65-100

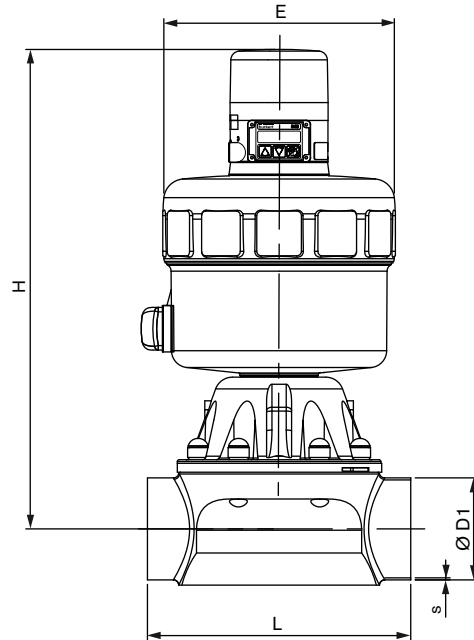

DN 15-50

Port connection [mm] [inch]	Actuator size [mm]	E	H	L	EN ISO 1127/ ISO 4200		DIN 11850								SMS 3008		JIS		ASME BPE		
					D1	s	Series 0		Series 1		Series 2		Series 3		D1	s	D1	s	L	D1	s
15 1/2"	80	101	278	110	21.3	1.6	18	1.5	18	1	19	1.5	20	2	-	-	21.7	2.1	108	12.7	1.65
20 3/4"	80	101	289	119	26.9	1.6	22	1.5	22	1	23	1.5	24	2	-	-	27.2	2.1	117	19.05	1.65
25 1"	80	101	292	129	33.7	2	28	1.5	28	1	29	1.5	30	2	25	1.2	25.4	1.2	127	25.4	1.65
40 1 1/2"	125	153	389	161	48.3	2	40	1.5	40	1	41	1.5	42	2	38	1.2	38.1	1.2	159	38.1	1.65
50 2"	125	153	393	192	60.3	2	52	1.5	52	1	53	1.5	54	2	51	1.2	50.8	1.5	190	50.8	1.65

DN 65-100

Port connection [mm] [inch]	Actuator size [mm]	E	H	L	EN ISO 1127/ ISO 4200		DIN 11850 Series 1		SMS/ASME BPE		
					D1	s	D1	s	L	D1	s
65 -	125	153	512	250	76.1	2	70	2	-	-	-
-	175	211	524	250	76.1	2	70	2	-	-	-
80 3"	175	211	524	250	88.9	2.3	85	2	250	76.2	1.65
100 4"	225	261	539	295	114.3	2.3	104	2	295	101.6	2.11

Dimensions for valve system Continuous Classic Type 8802-DD [mm], continued

Dimensions valve system Continuous Classic 8802-DD-C with positioner SideControl Type 8635 [mm]

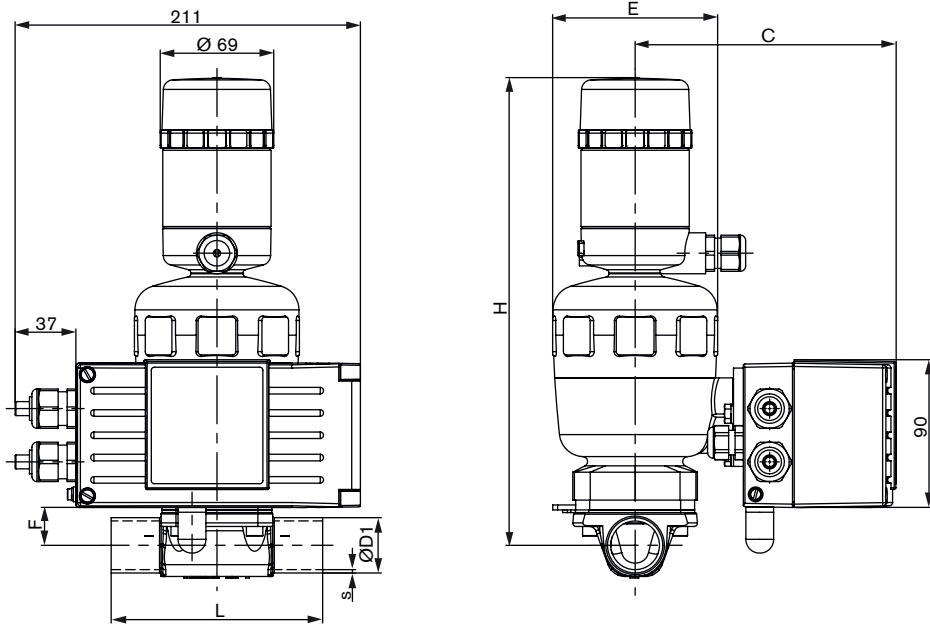

EN ISO 1127/ISO 4200, DIN 11850, SMS 3008, JIS

Port connection		Actuator size [mm]	E	H	F	C	L	EN ISO 1127/ ISO 4200		DIN 11850								SMS 3008		JIS	
[mm]	[inch]							D1	s	Series 0		Series 1		Series 2		Series 3		D1	s	D1	s
15	1/2"	80	101	262	14	159	110	21.3	1.6	18	1.5	18	1	19	1.5	20	2	-	-	21.7	2.1
20	3/4"	80	101	267	18	159	119	26.9	1.6	22	1.5	22	1	23	1.5	24	2	-	-	27.2	2.1
25	1"	80	101	270	23	159	129	33.7	2	28	1.5	28	1	29	1.5	30	2	25	1.2	25.4	1.2
40	1 1/2"	125	153	366	50	185	161	48.3	2	40	1.5	40	1	41	1.5	42	2	38	1.2	38.1	1.2
50	2"	125	153	372	54	185	192	60.3	2	52	1.5	52	1	53	1.5	54	2	51	1.2	50.8	1.5

ASME BPE

Port connection		Actuator size [mm]	E	H	F	C	L	ASME BPE		
[mm]	[Zoll]							L	D1	s
15	1/2"	80	101	262	14	159	110	108	12.7	1.65
20	3/4"	80	101	267	18	159	119	117	19.05	1.65
25	1"	80	101	270	23	159	129	127	25.4	1.65
40	1 1/2"	125	153	366	50	185	161	159	38.1	1.65
50	2"	125	153	372	54	185	192	190	50.8	1.65

Dimensions for valve system Continuous Classic Type 8802-DD [mm], continued

Dimensions valve system Continuous Classic 8802-DD-P with Positioner SideControl Remote Type 8792 and Type 8802-DD-Q with Process Controller SideControl Remote Type 8793 [mm]

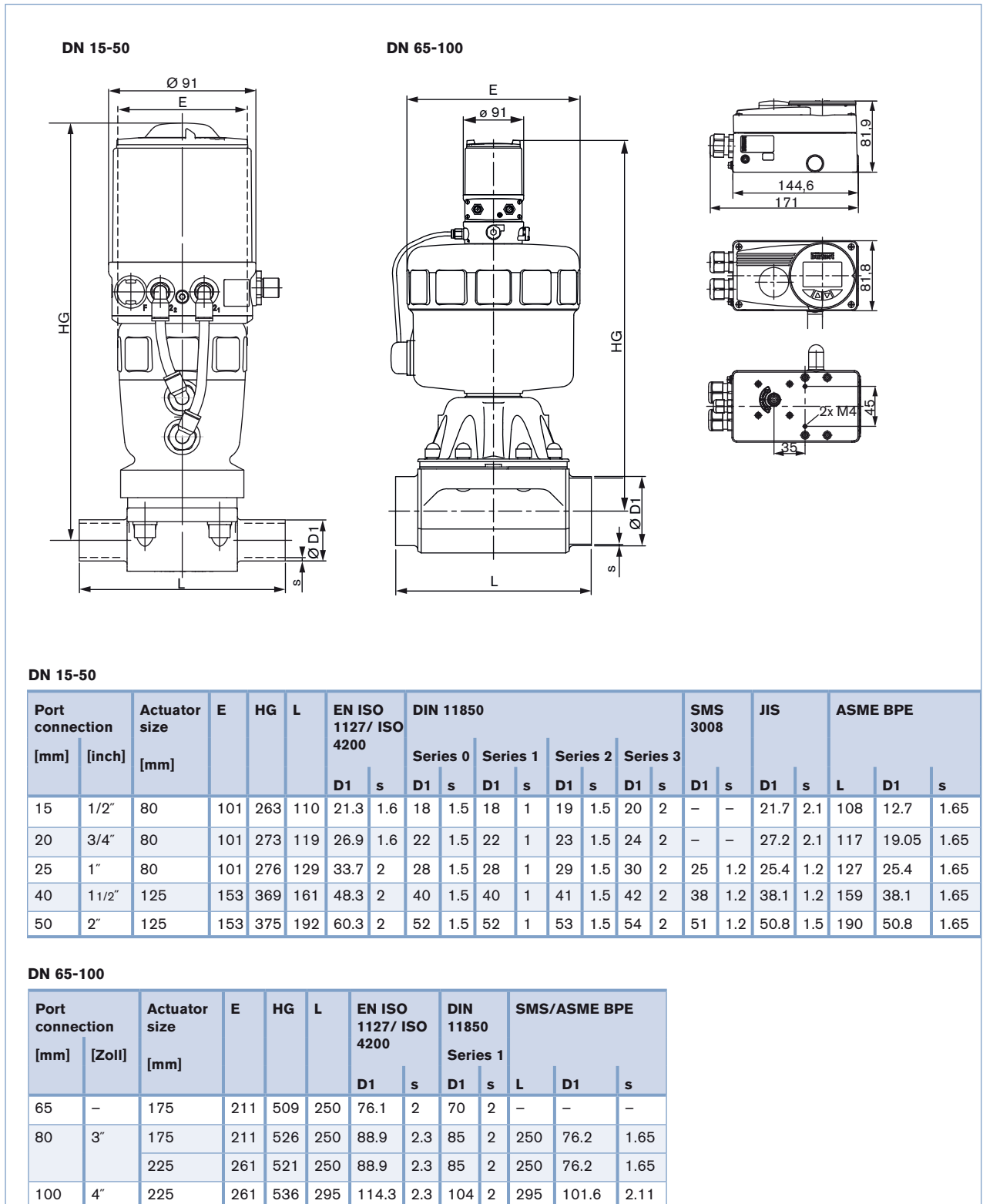

Note

You can fill out the fields directly in the PDF file before printing out the form.

Valve system Continuous Classic Type 8802-DD - Request for quotation

▶ Please fill out and send to your nearest Bürkert facility* with your inquiry or order

Company	Contact person
Customer no.	Department
Address	Tel./Fax
Postcode/town	E-Mail

= mandatory fields to fill out

Quantity

Required delivery date

Operating data

Pipeline	DN	<input type="text"/>	PN	<input type="text"/>
Pipe material	<input type="text"/>			
<input checked="" type="checkbox"/> Process medium	<input type="text"/>			
<input checked="" type="checkbox"/> Type of media	<input type="checkbox"/> Liquid	<input type="checkbox"/> Steam	<input type="checkbox"/> Gas	
	min	standard	max	unit
<input checked="" type="checkbox"/> Flow rate (Q, Q _N , W) ¹⁾	<input type="text"/>	<input type="text"/>	<input type="text"/>	<input type="text"/>
<input checked="" type="checkbox"/> Temperature at valve inlet	<input type="text"/>	<input type="text"/>	<input type="text"/>	<input type="text"/>
<input checked="" type="checkbox"/> Absolute pressure at valve inlet	<input type="text"/>	<input type="text"/>	<input type="text"/>	<input type="text"/>

¹⁾ standard unit: Liquid Q = m³/h; Steam W = kg/h; Gas Q_N = Nm³/h

Valve features

Specification key

automatically transferred from last page [go to page](#)

<input type="checkbox"/>	<input type="checkbox"/>	<input type="checkbox"/>	<input type="checkbox"/>	<input type="checkbox"/>	<input type="checkbox"/>	<input type="checkbox"/>	<input type="checkbox"/>
--------------------------	--------------------------	--------------------------	--------------------------	--------------------------	--------------------------	--------------------------	--------------------------

Surface finish (if not standard)

internal μm external μm

Pilot pressure

min. max.

continued next page

* To find your nearest Bürkert facility, click on the orange box →

www.burkert.com

