

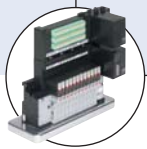

Type 2080 can be combined with...



**Type 8640**

AirLINE Quick



**Type 8036**

Flow sensor

## 2/2-way valve with PTFE bellows for fluid separation

- High Medium resistance
- Easy to clean for hygienic applications
- Long life
- Easy conversion of the actuator function, normally open/closed
- Compact
- With stainless steel actuator

The valve consists of a pneumatically piston actuator with return spring, a stainless steel body and PTFE bellows. The PTFE bellows are used for the separation of the medium. With the appropriate installation (body to bottom) the valve is self-draining. The materials used and the internal contours are simple to clean (CIP and SIP). The valve is suitable for food technology. The modular structure permits configuration with different armatures and customized port connectors. The pneumatic actuator is servo assisted by a pilot valve, a valve block or similar.

Technical data	
<b>Orifice</b>	DN 10, DN6 (flange), others on request
<b>Actuator size</b>	piston diam. 28mm
<b>Medium</b>	Neutral to aggressive gases and liquids
<b>Medium pressure range</b> <b>Medium temperature</b>	Vacuum up to 8 bar (see PT-Diagram)
<b>Port connections</b>	Threaded port G 3/8, weld end, flange connection
<b>Pilot air connections</b>	Threaded port G 1/8
<b>Position detection</b>	Reedcontact (two wire, closer), cable length: 3m
<b>Installation</b>	Upright assembly for self-draining (body to bottom)
<b>Body material</b>	Stainless steel 316Ti (1.4571), with flange 316L (1.4404)
<b>Actuator material</b>	Stainless steel 304L (1.4301)
<b>Bellows material</b>	Advanced PTFE
<b>Wetted materials</b>	Stainless steel 316Ti /316L, advanced PTFE
<b>Back pressure</b>	Tight to 8 bar
<b>Ground leakage</b>	5 Nml/min, measured with air 8 bar below seat
<b>Pilot air pressure</b>	4.5 to 10 bar
<b>Pilot fluid</b>	Neutral gases, air
<b>Ambient temperature</b>	Max. +90 °C
<b>Surface finish</b>	Surface finish Ra=0.8, others on request
<b>Special features</b>	- With self-draining operation - Suitable for CIP and SIP (cleaning in process) - Suitable for foodstuffs - FDA conform

<b>Flow rate</b> Kv value water [m <sup>3</sup> /h]	Measured at +20°C, 1 bar Pressure at valve inlet and free outlet
<b>Pressure values [bar]</b>	Overpressure with respect to atmospheric pressure
<b>Flow direction (liquids)</b>	below seat (pressure on port connection 2)

Material

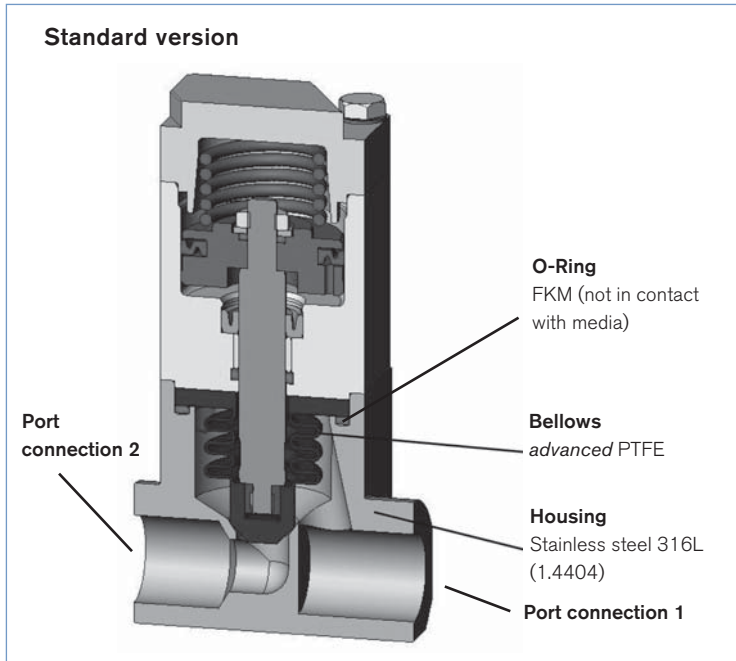

Pressure temperature characteristics

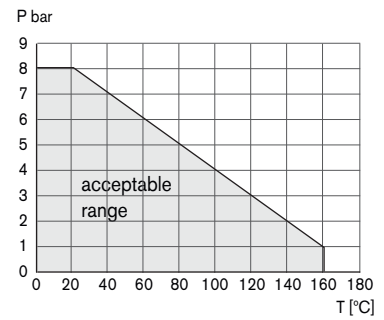

Ordering chart for valves (other versions on request)

All valves with pilot air ports G 1/8 and actuator body in stainless steel

Circuit function	Actuator version	Orifice [mm]	kv value [m <sup>3</sup> /h]	Medium connection	Item no.
<p><b>A</b></p> <p>2/2-way-valve, (NC), without pilot air closed by spring force</p>	On-Off	10	1.14	Threaded port G 3/8	180 729
		10	1.14	Weld end acc. to BS 4825 (12.7 x 1.2)	179 582
		10	1.14	Weld end acc. to ISO 4200 (13.5 x 1.6)	186 407
		10	1.14	Weld end acc. to DIN 11850-2 (13 x 1.5)	186 409
		6	0.64	Flange port	182 863
		–		without body (only actuator)	180 555

on request:

- normally open version (control function B, CF B)
- mechanical stroke limiter for safer flow adjustment (VAR CODE MJ33)
- 3-position actuator (VAR CODE MW14)

Dimensions [mm]

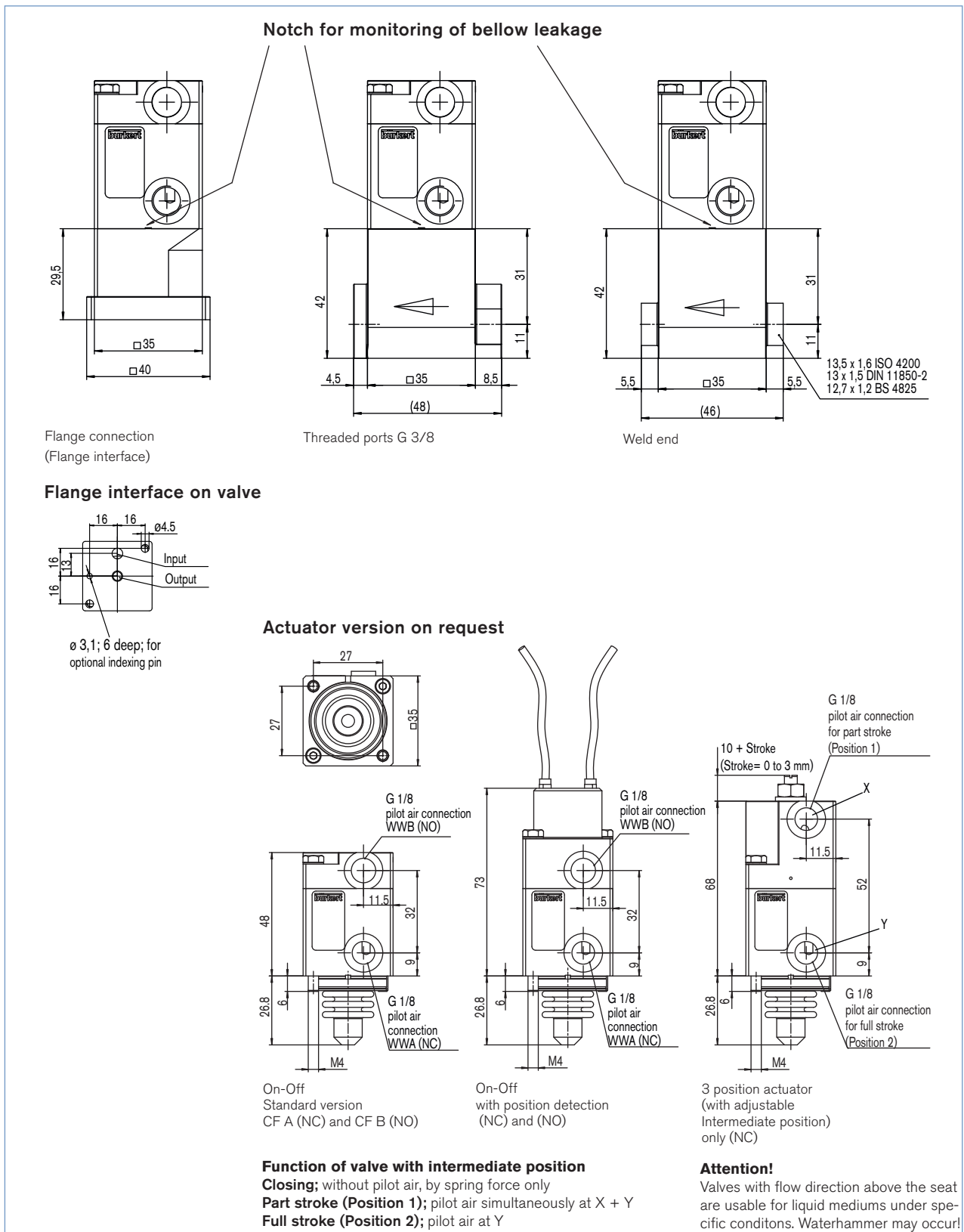

To find your nearest Bürkert facility, click on the orange box → [www.burkert.com](http://www.burkert.com)

In case of special application conditions, please consult for advice.

Subject to alterations  
 © Christian Bürkert GmbH & Co. KG

1203/6\_EU-en\_00895034